



## Fenix laser marker - high performance at a low price!

all the  
benefits of  
laser  
marking  
at an  
exceptionally  
low price!

Ideal for a wide range of product marking applications, Fenix is the first laser marker that can truly be considered a component. Easily incorporated into production processes, Fenix creates crisp, clear marks on plastics, metals, glass, wood, and countless other materials at speeds up to 225 characters per second.

The core of this compact system is Synrad's 48-2, 25-watt sealed CO<sub>2</sub> laser. We've paired it to a galvo-based marking head, and incorporated internal cooling fans and power supplies to create a complete, self-contained system. Simple to use and operate, just connect Fenix to a standard PC, plug it into the wall, and you're ready to start marking!

Fenix is operated by Synrad's own Windows<sup>®</sup>-based software, WinMark Pro<sup>®</sup>. This easy-to-use software, with its familiar pull-down menus and dialog boxes, enables users to perform a wide variety of marking functions, including automated functions such as serialization and bar coding.

Priced about 1/3 less than comparable laser markers, Fenix offers an unprecedented combination of high performance and low cost!



An Excel Technology Company

# Fenix Laser Marker

Marking Specifications	Focusing Lens Size			
	370mm	200mm	125mm	80mm
Field Size, typical (mm)	200 x 200	110 x 110	70 x 70	27 x 27
Spot Size, $1/e^2$ ( $\mu\text{m}$ )	540	290	180	116
Working Distance <sup>1</sup> , typical (mm)	350 $\pm$ 5	190 $\pm$ 3	128 $\pm$ 2	74 $\pm$ 1
Depth of Field, typical (mm)	$\pm$ 10	$\pm$ 2.5	$\pm$ 1.5	$\pm$ 0.4
Incident Angle, max	19	16	12	5
Marking Speed <sup>2</sup> (characters / sec, max)	225	225	225	225
Position Accuracy (mm)	0.05	0.03	0.02	0.01
Position Resolution ( $\mu\text{m}$ )	<15	<9	<6	<3
Repeatability (mm)	0.063	0.038	0.025	0.015
Settling Time, Small Step - 1% of field (ms)	<0.8	<0.8	<0.8	<0.8

<sup>1</sup>A nominal working distance is marked on each individual focusing lens mount since this distance may vary from lens to lens up to  $\pm$ 10 mm. For this reason, it is important to provide a Z-axis adjustment between the marking head and the marking surface.

<sup>2</sup>Character height ~3mm, lens dependent.

Input Requirements	
Input Power	AC 85-132 V/ 170-264 V, 1 $\phi$ (Universal Mains Voltage)
Input Fuse Rating	10A, 250 VAC

Dimensions	
Length x Width x Height (in)	46.67 x 9.66 x 7.39
(mm)	1185 x 245 x 188
Weight (lbs)	62
(kg)	28.1

Specifications subject to change without notice

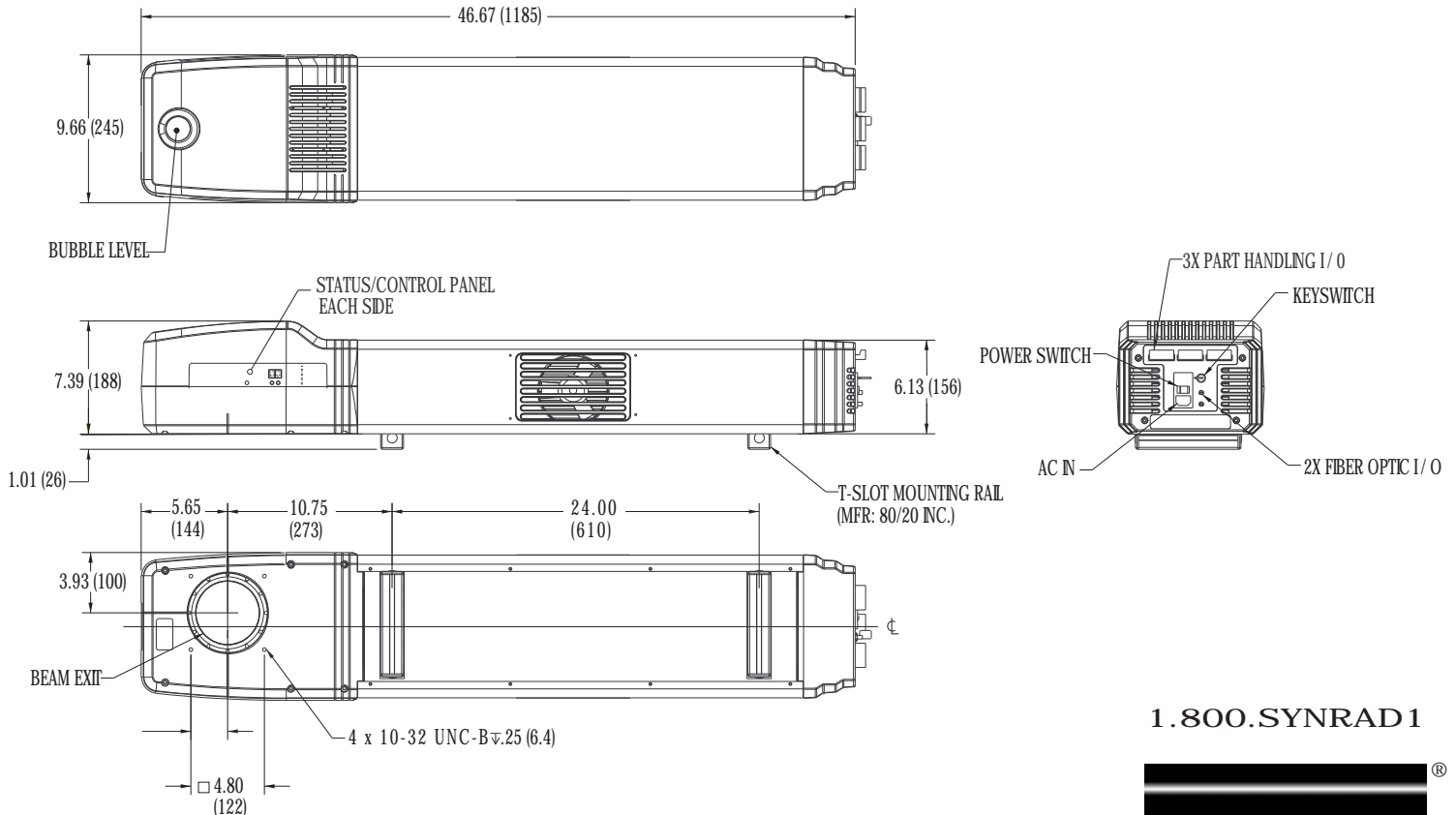

1.800.SYNRAD1



Dimensions are in inches (millimeters)